



TORNOS

*We connect you
to success across
myriad electronics
applications.*

ELECTRONICS

Worldwide mobile subscriptions and data traffic

1 Compound Annual Growth Rate (CAGR)
2 Long Term Evolution (LTE)

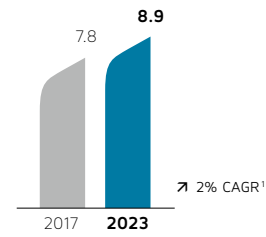

Worldwide mobile subscriptions
In billions

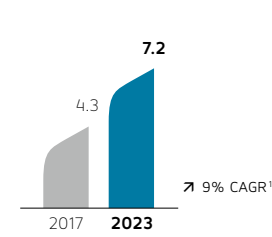

Worldwide smartphone subscriptions
In billions

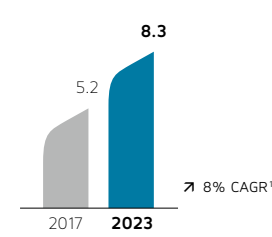

Worldwide mobile broadband subscriptions
In billions

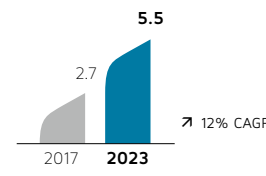

Worldwide LTE² subscriptions
In billions

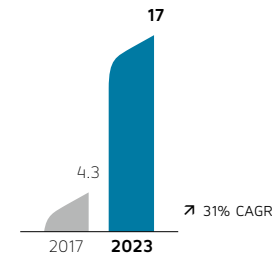

Worldwide monthly data traffic per active smartphone
In gigabytes

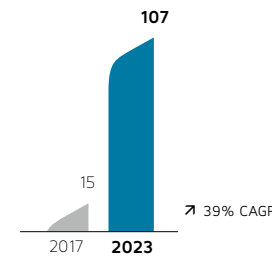

Worldwide total monthly mobile data traffic
In exabytes

IoT connections outlook

Connected devices in billions

1 Compound Annual Growth Rate (CAGR)
2 Internet of Things (IoT)

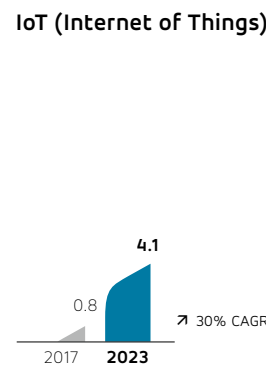

Wide-area IoT
In billions

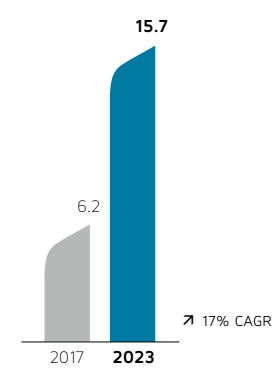

Short-range IoT
In billions

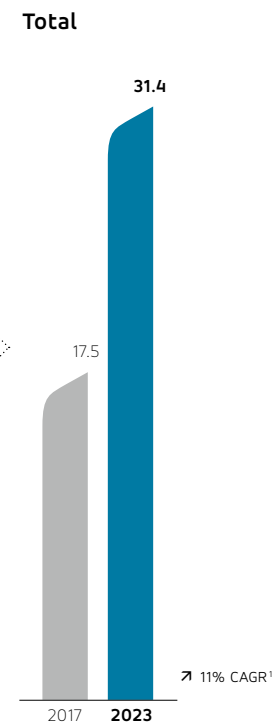

Total connected devices
In billions

Other devices

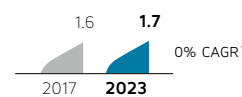

PC / laptop / tablet
In billions

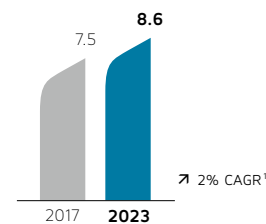

Mobile phones
In billions

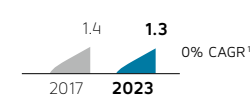

Fixed phones
In billions

Network coverage

In 2023, more than 20 percent of the world's population will be covered by 5G.

3GPP cellular technologies



LTE



5G

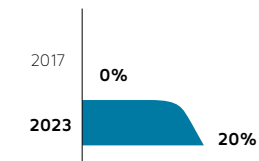

Development of the global population

The global population will grow, but the speed of growth is slowing down.

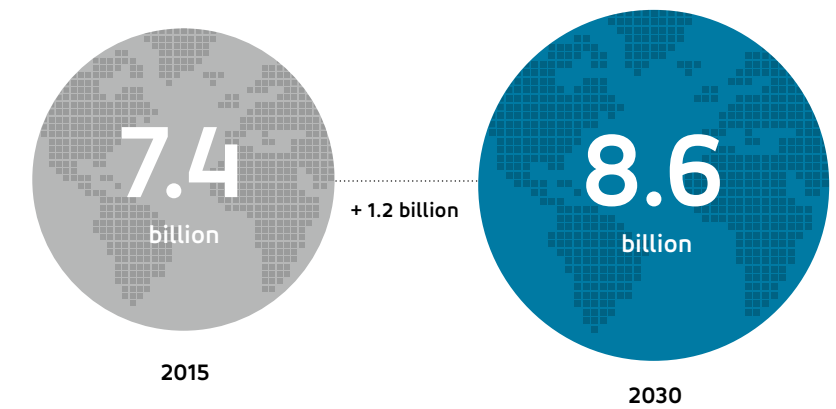

- The world population is projected to increase to **8.6 billion in 2030**, up 16% from **7.4 billion today**¹. In **2000**, the world population was **6.1 billion** – 20% less than today
- Compared to the population growth of the past 15 years, the speed of growth is slowing down. Between 2000 and 2015, the population grew by 1.2% or 83 million people p.a., whereas the average annual growth rate between 2015 and 2030 is expected to drop below 1% (0.98% or 78 million people p.a.)

Notes: Data from the UN World Population Prospects: The 2017 Revision; estimates are based on the medium-variant projection

¹ Today refers to 2015 data here and on all subsequent slides.

Source: UN DESA

An increasingly connected world

KEY MEGATRENDS DRIVE DEMAND FOR GREATER CONNECTIVITY IN EVERYTHING FROM CONSUMER ELECTRONICS, AUTOMOTIVE AND MEDTECH TO THE FACTORIES OF THE FUTURE.

A global innovation boom in connectivity is underway, with remarkable strides being made in everything from connected clothing and consumer electronics to medtech, energy, automotive and industrial applications. Connected medical devices, smart cities leveraging data and technology to achieve efficiency, sustainability, economic development and greater life quality, connected cars, and the Industrial Internet of Things (IIoT) are just a few examples.

Global electrical and electronics production in 2015 was valued at €4 trillion, with China claiming an overwhelming 51 percent lead as the world's top producer of electrical and electronic goods. China's electrical and electronic industry growth was set to grow by 6 percent in 2018.¹

Key megatrends—global, sustained and macroeconomic forces of development that impact business, economy, cultures and personal lives²—are driving global electronics industry growth. These trends include shifting demographics, globalization, and, particularly, technology and innovation.

Changing demographics

Shifting demographics promise to significantly impact industries like electronics, whose lifeblood is linked to technology and innovation. Among these changing demographics are world population growth: The global population is set to grow by 1.2 billion—a 16 percent increase—by 2030,³ primarily due to growth in developing nations. Decreasing populations in developed nations present the dilemma of **skills shortages due to retiring baby boomers and a gap in talent to support global digital transformation.**⁴

The global population is also aging: The median age globally will increase by 3.4 years by 2030 and 50 percent of the world's population will be older than 33 years. In the developed world, the median age in 2030 will be 44 (31.2 in the developing world). The global population aged 60 or older was 962 million in 2017—more than double 1980's 382 million people 60 and older; the number of older people is set to double again by 2050 to nearly 2.1 billion.⁵ **The aging population creates opportunities for companies selling medical products and devices**, since people 65 and older account for the majority of medical device use⁶. To illustrate these opportunities: Cardiovascular devices such as pacemakers and implantable cardioverter-defibrillators contribute to a cardiovascular market valued at US \$33.8 billion⁷. **Populating aging also adds to the demand for smarter, safer vehicles**, building on existing safety features like semi-autonomous and autonomous vehicles, and

existing safety features like traction control, lane support and autonomous braking⁸, all of which demand electronic components.

Urbanization is yet another demographic dynamic poised to drive growth in electronics uptake and manufacturing. Today, for the first time in history, more than 50 percent of the global population lives in urban areas, and that figure will climb to 70 percent by 2050.⁹ Increased urbanization threatens to strain infrastructures and economic and natural resources—but **smart cities are emerging to answer the challenges of urbanization** by using digital and telecommunication technologies to increase the efficiency of traditional networks and services.¹⁰ Imagine cities where street lights come on only when someone is within their range, where all available parking options are available at the touch of a finger, and where it's easy to interact with the city's infrastructure—by reporting a pothole in the road, for example. That's the vision of smart cities: smarter urban transportation, improved water supplies and waste disposal, and greater energy efficiency.

US \$33.8 billion cardiovascular market

Globalization

Rising gross domestic product (GDP) and household income are driving growth of the global middle class. **GDP growth increases demand for both global brands and frugal products**¹¹: smart phones, wearable electronics, smart energy solutions for homes, smarter and more comfortable cars, as well as electronics for industry and infrastructure. On one hand, exports are expected to grow faster than GDP in advanced economies. In developing markets, the opposite is true.

In Brazil, Russia, India, China and South Africa—the BRICS countries—an astounding 100 percent rise in real GDP in purchasing power parity (PPP) is expected by 2030, with China and India becoming the dominant players in terms of global GDP share and disposable income.¹² Furthermore, the BRICS' nominal GDP is expected to triple by 2030.¹³ Shaping the landscape of emerging markets—and the electronics sector—are a number of fast-growing country clusters: the Next 11 (Bangladesh, Egypt, Indonesia, Iran, Mexico, Nigeria, Pakistan, Philippines, Turkey, South Korea and Vietnam), MINT (Mexico, Indonesia, Nigeria, Turkey) and MIST (Mexico, Indonesia, South Korea and Turkey). Accelerating their development are quickly increasing GDP, burgeoning middle class, and fast-growing GDP per capita—and, though there are exceptions, most have a young, fast-growing population.

1 ZVEI: Die Elektroindustrie, *The Global Electrical & Electronic Industry—Facts & Figures*, July 2017

2 Frost & Sullivan, <https://www2.frost.com/consulting/consulting-toolbox/mega-trends-ideation/>

3 Roland Berger, *Trend Compendium 2030*

4 Ibid.

5 United Nations, *World Population Ageing [highlights]*, p. 1

6 UBS, *Longer Term Investment*, April 7, 2017, p. 1-2

7 UBS, *Longer Term Investment*, April 7, 2017, p. 4

8 Kota Yuzawa, Patrick Archambault, Stefan Burgstaller, Bill Shope, Heather Bellini, *Cars 2025: Vol. 1, A disruptive new era of the Automotive Age*, (New York: Goldman Sachs Global Investment Research, 2015), p. 8

9 World Health Organization, *Bulletin of the World Health Organization: Urbanization and health*, <http://www.who.int/bulletin/volumes/88/4/10-010410/en/>

10 European Commission, "What are smart cities?" https://ec.europa.eu/info/eu-regional-and-urban-development/topics/cities-and-urban-development/city-initiatives/smart-cities_en

11 Ibid.

12 Roland Berger, *Trend Compendium 2030: Globalization and future markets*, p. 31

13 Roland Berger, *Trend Compendium 2030: Globalization and future markets*, p. 22

Technology and innovation

Both driven by prosperity and a key driver of prosperity, technology and innovation present the potential of solving an array of global challenges, such as knowledge diffusion, environmental concerns, scarcity of natural resources and health care. Innovation is the fruit of technology, and **technology is being diffused globally at faster pace than ever before**. A key enabler has been the mobile technology industry: Its steady expansion has led to fundamental changes in society and it appears that 2018 will be remembered as the start of an even larger societal transformation. The Internet of Things—a vast network of physical devices and other items with embedded electronics, software, sensors, actuators and connectivity—will be further expanded by the rollouts of 5G networks and large-scale cellular networks. By 2023, there will be 3.5 billion cellular IoT connections and 1 billion 5G subscriptions¹⁵, promising to further ramp up the ongoing global digital transformation.

Forecasters expect **20.4 billion connected “things” to be in use worldwide in by 2020**, with Greater China, North America and Western Europe are driving the use of connected things.¹⁶ In addition to enabling smarter cities, improving public health and agriculture, reducing waste of food and resources¹⁷, the IoT—known as the Industrial Internet of Things (IIoT) in the context of industry—and the unfolding digital transformation stand to transform global manufacturing. The IIoT brings together intelligent machines, advanced analytics and people. Backed by a network of devices connected by communications technologies able to monitor, collect, exchange, analyze and deliver valuable new insights, the IoT gives rise to Industry 4.0, the Fourth Industrial Revolution or smart factors, with the potential to drive smarter, faster business decisions for industrial companies.¹⁸

It's an exciting—and challenging—time to be part of the electronics manufacturing value chain. Central to technological innovation and continuing global growth, the electronics industry feeds nearly every other industry through a complex, globally connected supply chain. Even with the opportunities presented by high demand, electronics manufacturers face all-too-real challenges: the ability to meet demand with highest quality and efficiency, short innovation cycles and product lifetimes, cost management, and fast return on their capital machine investments.

1 billion 5G
subscriptions
by 2023

¹⁴ Roland Berger, *Trend Compendium 2030, Globalization and future markets*, p. 24

¹⁵ Ericsson, *Ericsson Mobility Report*, June 2018, p. 2

¹⁶ Gartner, "Gartner Says that 8.4 Billion Connected 'Things' Will Be in Use in 2017, Up 31 Percent from 2016," February 7, 2017, <https://www.gartner.com/newsroom/id/3598917>

¹⁷ World Economic Forum, "Six Ways the Internet of Things is improving our lives," <https://www.weforum.org/agenda/2018/01/6-ways-the-internet-of-things-is-improving-our-lives/>

¹⁸ GE, "What is the Industrial Internet of Things?" <https://www.ge.com/digital/blog/everything-you-need-know-about-industrial-internet-things>

We keep you turning

A market as big as the world

There is no industry bigger than the electronics industry, due in large part to the fact that electronics are the lifeblood of ever-advancing technology. From medtech, automotive and entertainment to energy and food production and manufacturing (including robots, vacuum technology and measurement), every electronics sector and application has its own characteristics and requirements. Like no other strategic partner, Tornos has the expertise to analyze your real requirements and expectations and deliver the most thorough, solution-oriented advances to drive your quality, efficient productivity, turnaround time, return on investment and overall profitability. Behind every convenience in daily life, there is an electronics application, and behind every electronics application, there is a Tornos solution. That's how and why we live our brand promise: We keep you turning. And that's why electronics manufacturers worldwide turn to Tornos for single-and multispindle automatic lathes, micro-milling solutions and software, as well as a universe of world-class services.

Tornos and electronics

Automation and miniaturization and connectivity permeate our daily lives, from connecting our electrical devices to power sockets for connecting various components of our computers and electronic entertainment systems. Like the automotive and medical industries, the electronics industry benefits from technological advances in bar turning. Ever-greater customization of each connector, standardization of mass-market products and changing needs in terms of miniaturization are all challenges faced every day by our customers, giving rise to very specific technical requirements.

At the same time, given ever-increasing demand, electronics manufacturers are under pressure to accelerate mass production while reducing costs. The connectivity business requires highly automated industrial tools in order to produce increasingly sophisticated components on a large scale. Today's connectors demand advanced machining knowledge which is increasingly targeted and precise. Advanced knowledge of machinable materials—aluminum, polyether ether ketone (PEEK), the toughest stainless steels, titanium and cobalt-chrome—and machining are must-haves, and your production techniques must be innovative and immediately responsive to market demands. Tornos' well-established solutions connect you to success in this very demanding sector.



We help you master the tiniest parts

NO TEST PROBE APPLICATION IS TOO SMALL WHEN YOU TURN TO TORNOS—THE SMALL PARTS MASTER FOR MORE THAN 125 YEARS—FOR SOLUTIONS, SERVICE AND SUPPORT.

A test probe is a physical device used to connect electronic test equipment to a device under test (DUT). Test probes range from very simple, robust devices to complex, sophisticated, costly and fragile probes.

As electronic devices become smaller, circuits and electronics' circuit cards become smaller, too. Tornos' is renowned for its dedication to helping customers produce the tiniest parts: Our solutions enable you to produce test probes thinner than a human hair.

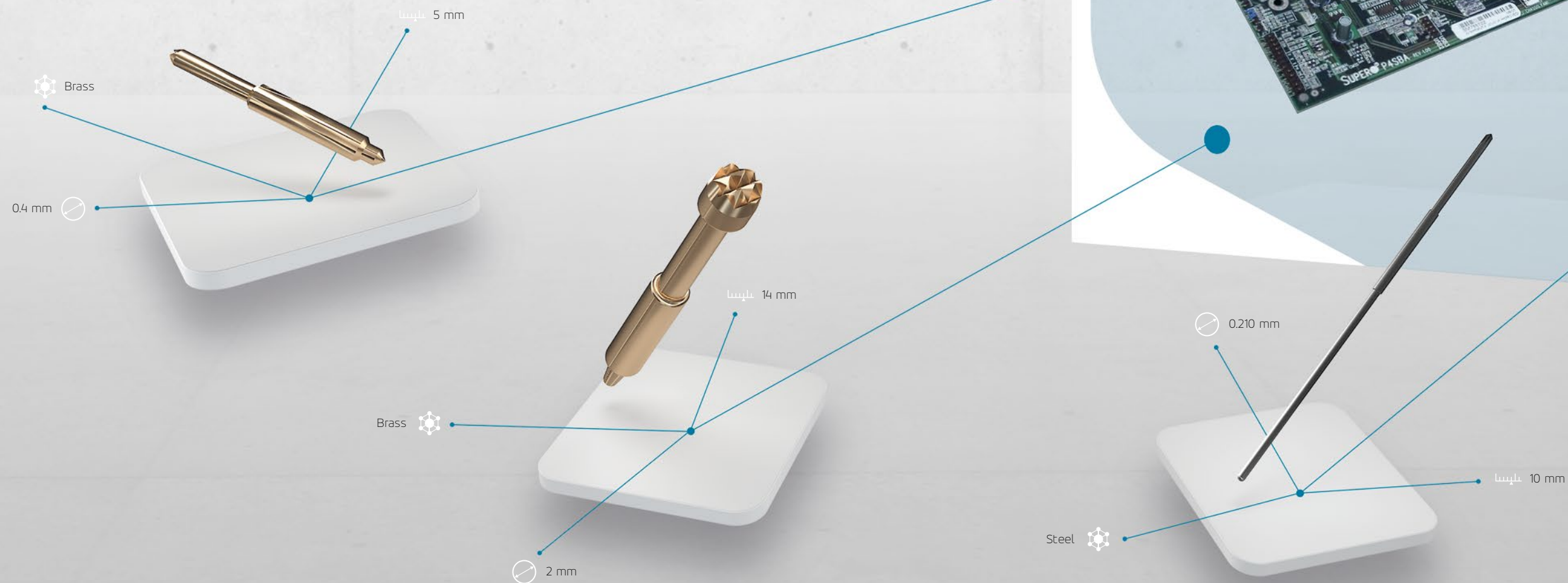
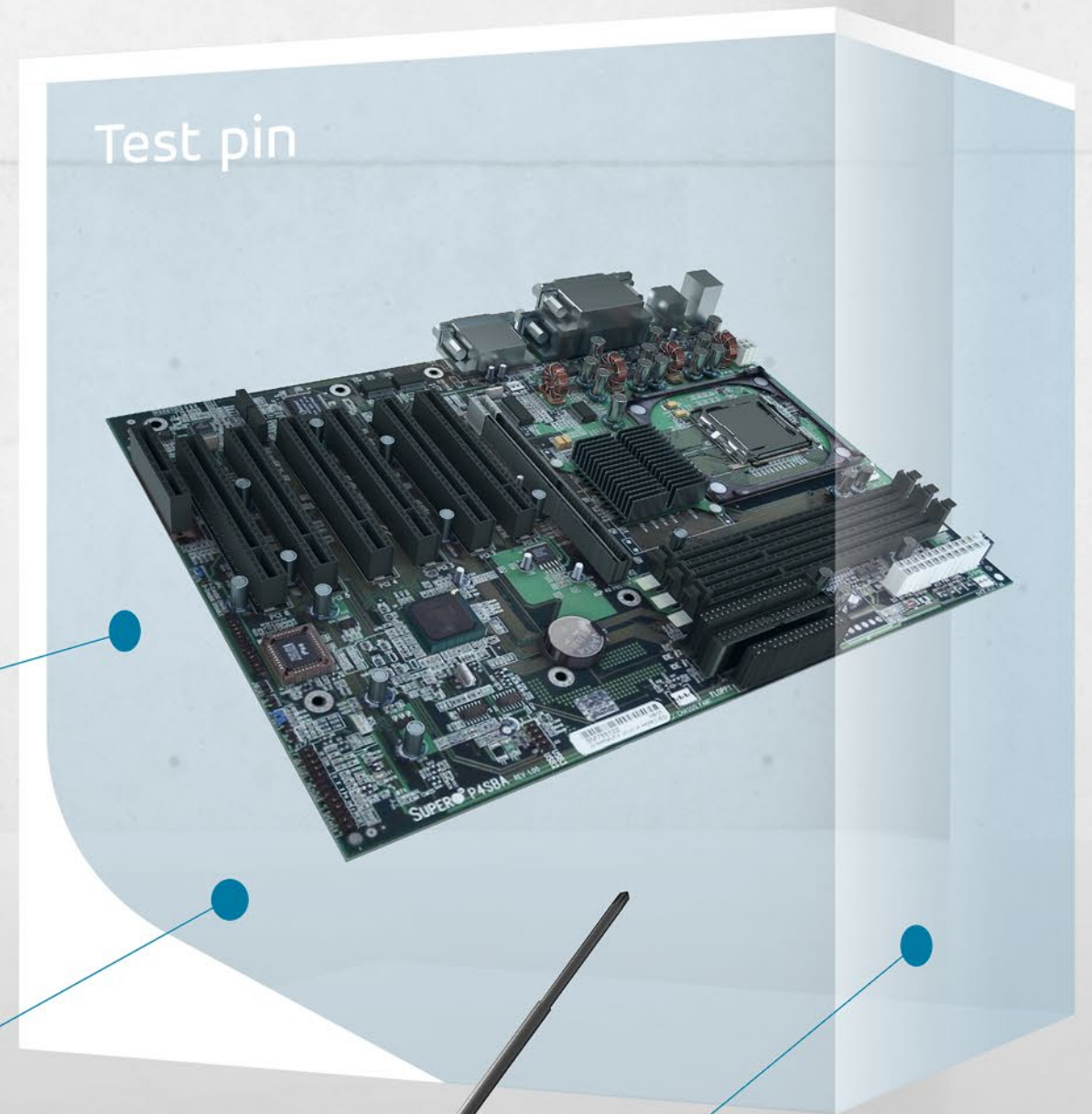

Take charge of rising demand —with Tornos

AS DEMAND FOR ELECTRICAL CONNECTORS INCREASES DUE TO THE RISE OF E-MOBILITY, TORNOS' SWISS-TYPE AND MULTISPINDLE LATHES CONNECT YOU TO SUCCESS.

Electrical sockets include several connectors, male or female. With the new e-mobility paradigm, the volume of these parts is increasing. Our Swiss-type and multispindle solutions are ready to tackle those challenges, whether your parts are made of classical brass, Inconel or copper.

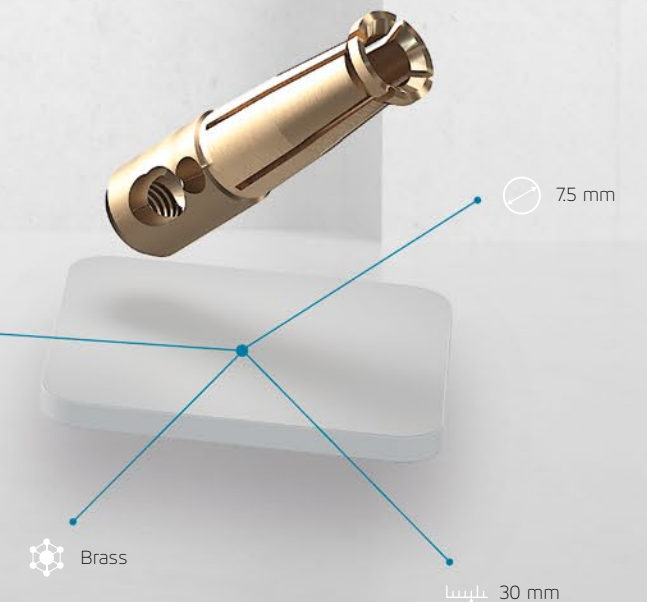
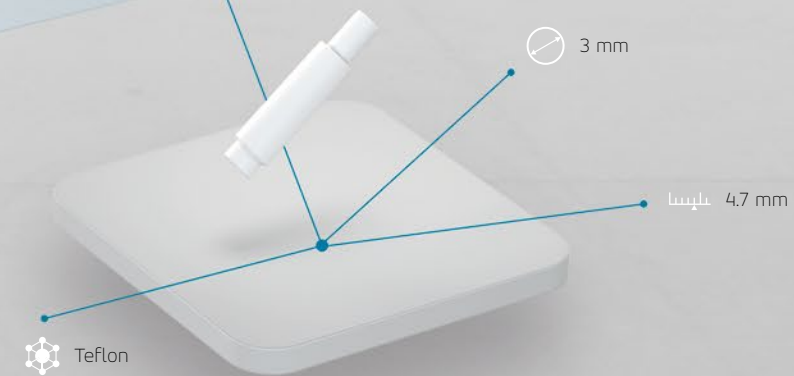
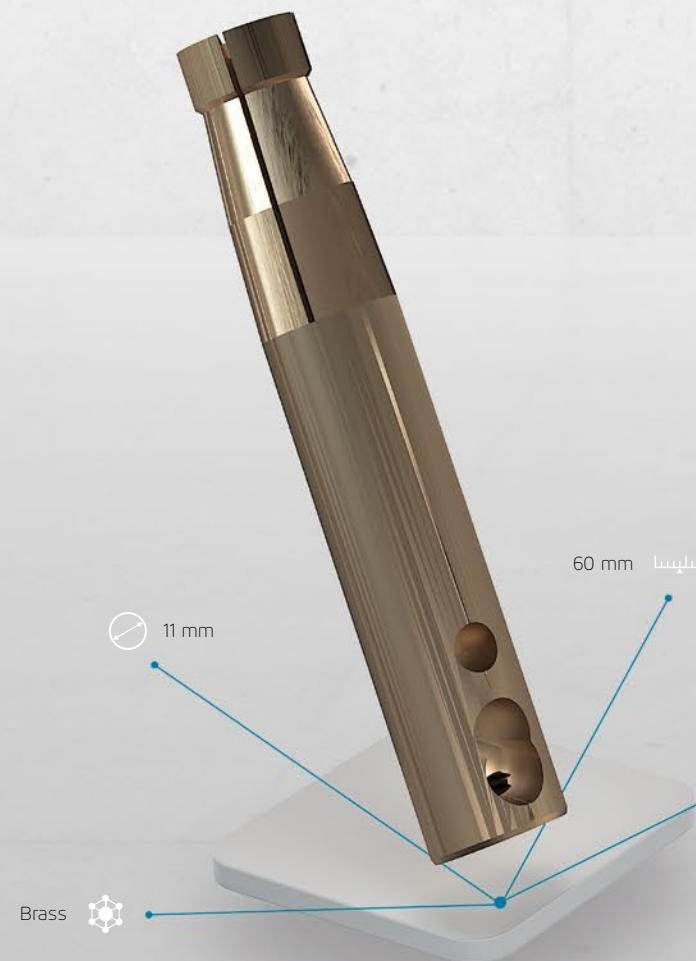
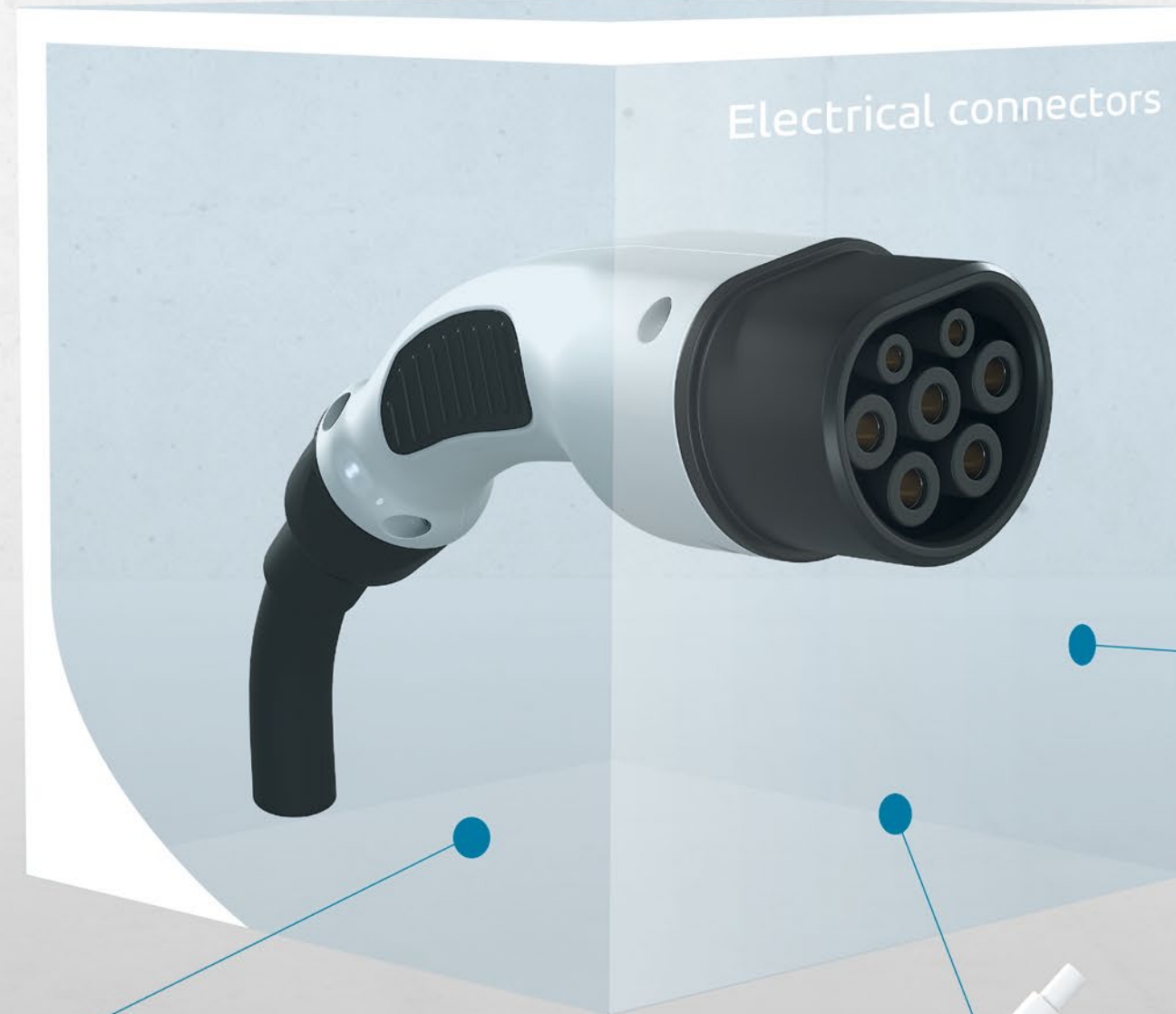

Protect your connectors and sensors

PERFECTLY EXECUTED CONNECTOR AND SENSOR HOUSINGS PROTECT AND EXTEND THE LIFETIMES OF THESE CRUCIAL ELECTRONIC COMPONENTS—AND WHEN IT COMES TO PRODUCING THEM, NO ONE SUPPORTS YOU LIKE TORNOS.

Connectors can be found everywhere: in subways, nuclear power plants, race cars and communications equipment, for example. Connector bodies are a crucial part of a connector, protecting and ensure long service life of the connector.

Tornos' significant expertise in part finishing and materials is your advantage in the manufacture of connector and sensor bodies. Naturally, this includes production of insulators—in PEEK, for example—for the connectors.

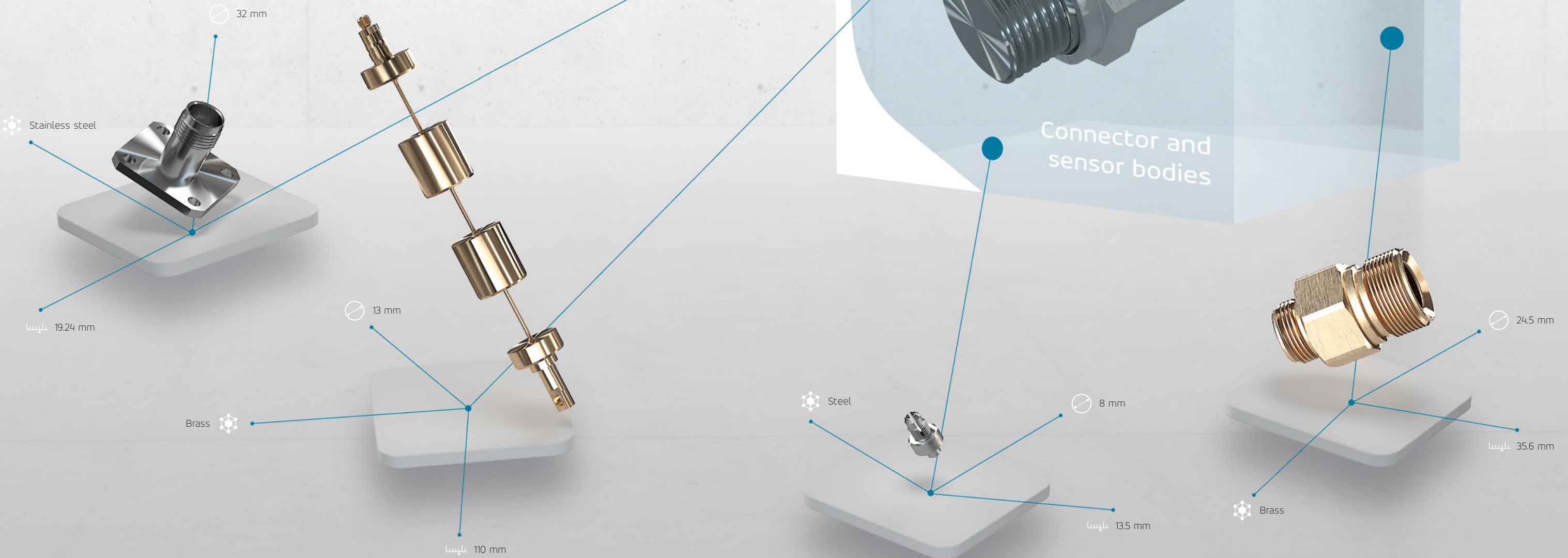

We help you produce perfect high-end connectors

AS THE TREND TOWARD MINIATURIZATION CONTINUES IN HIGH-END CONNECTOR APPLICATIONS, TORNOS HAS YOU COVERED, WHATEVER THE PART GEOMETRY.

These connectors are in the heart of each high-end connection, assuring the perfect match for a perfect connection. Miniaturization is trend that's here to stay in this application and Tornos' is the master of small parts. Round, square or essentially any other shape of connector or sensor, we provide comprehensive solutions. Our solutions usually come into play at the base of the connection of the safety sensors, protecting you while you're using industrial equipment.

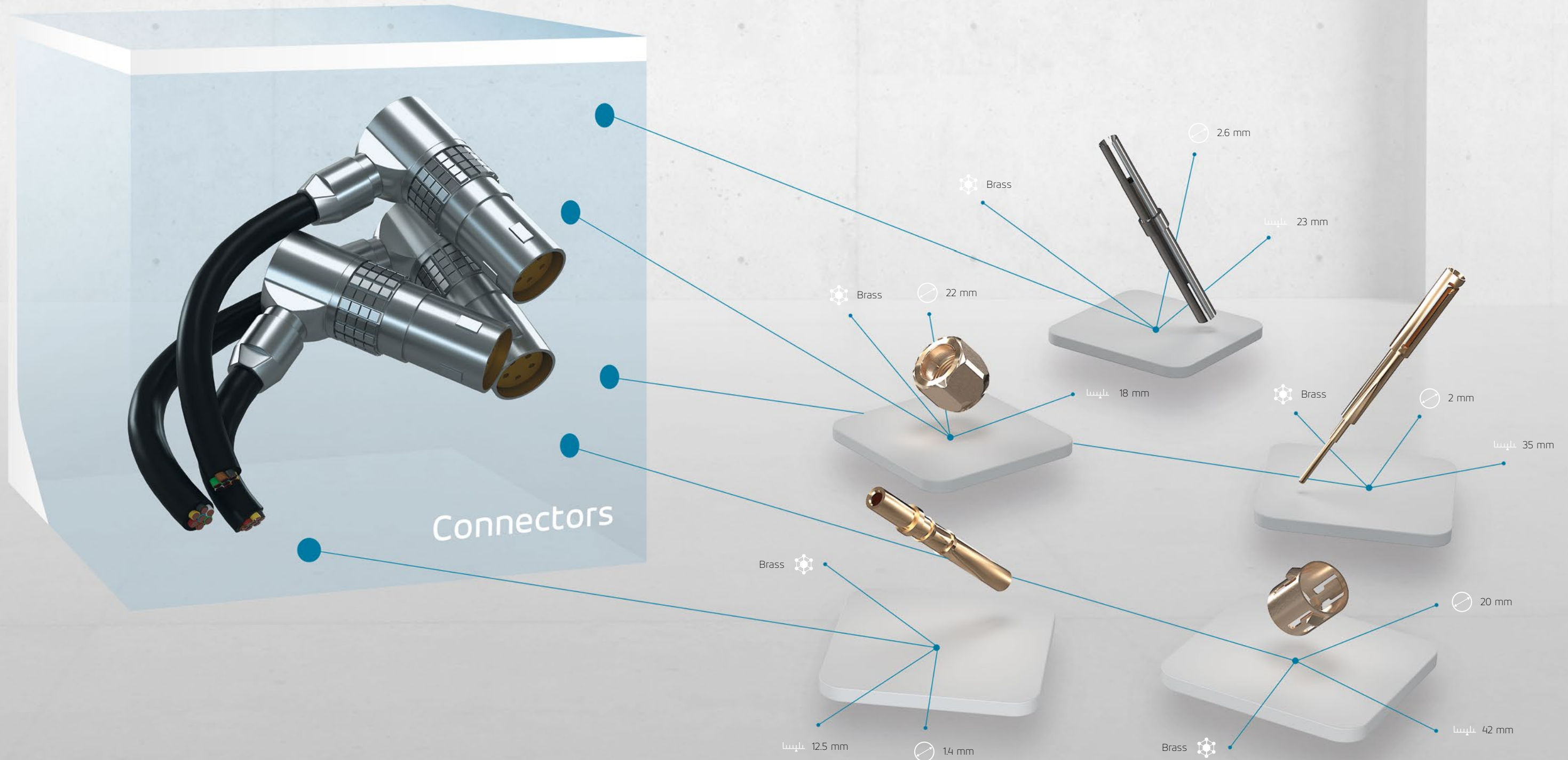

Confidently produce a wide array of robotics components

AUTOMATION IS THE FUTURE, AND ROBOTICS PLAY A CENTRAL ROLE. LOOK TO TORNOS FOR UNPARALLELLED SOLUTIONS AND EXPERTISE FOR PRODUCING HYDRAULICS, PNEUMATICS, VALVES AND FITTINGS FOR ROBOTS.

From hydraulic fluid and water to air that needs to be driven through a series of connections or stopped through a tap, Tornos has a legacy of experience in the production of hydraulics parts including spools, pneumatics, valves and fittings for robots. Whether you are manufacturing six-axis robots or agricultural equipment, Tornos has the turning solutions and application expertise to drive your success.

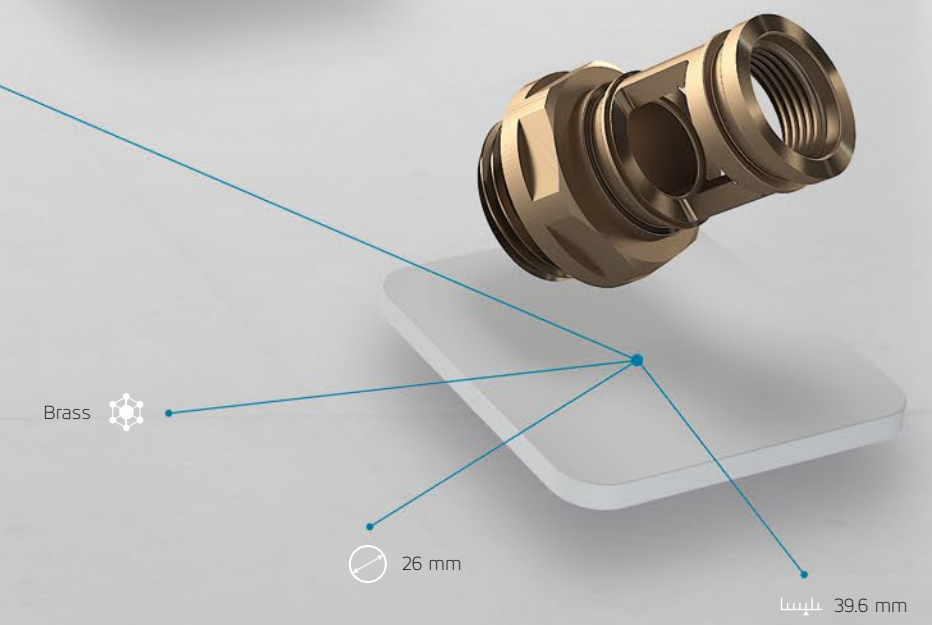
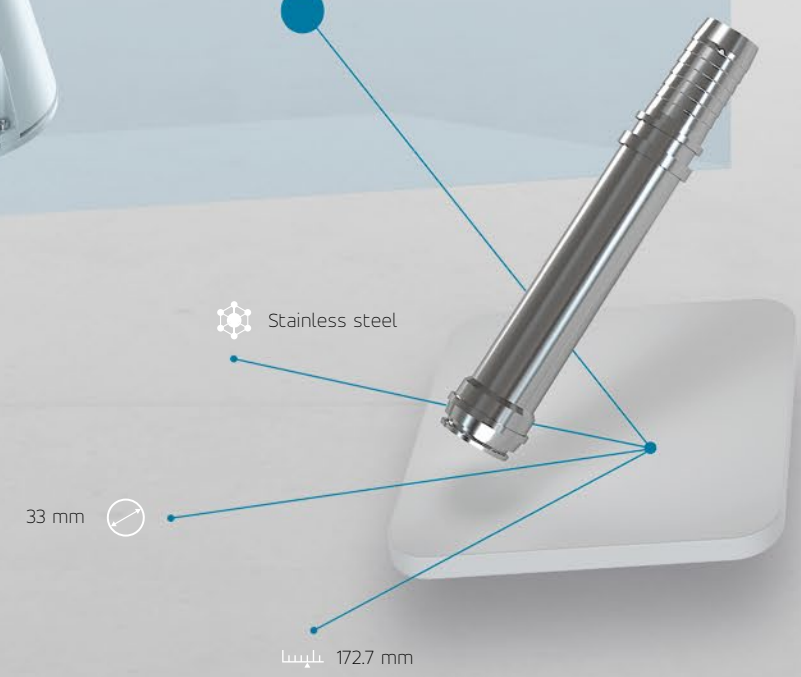
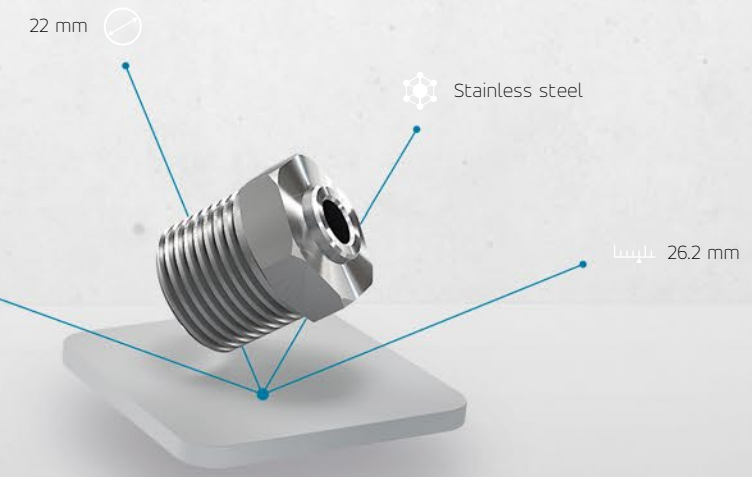

A hand is shown holding a small, green, square-shaped printed circuit board (PCB) component. The background is a blurred view of a complex electronic assembly, likely a multi-spindle machine, with various components, wires, and mechanical parts visible. The lighting is blue and focused on the hand and the component it is holding.

We meet our customers' challenges with a legacy of electronics expertise.

Electronics challenges

Manufacturers of electronic components face a wide spectrum of challenges: increasing miniaturization, harder-to-machine materials like Inconel, stainless steel and titanium, flawless surface finishes for fiber optic connectors, and rising pressure to reduce manufacturing costs. Challenges are further compounded by specific sector demands. Depending on the sector—medical, data, transportation, communications or light-emitting diodes (LEDs)—high customization may be required. At the same time, the demand for standard connectors continues to grow.

Tornos answers

Like no other partner, Tornos answers those challenges with more than 125 years of small parts manufacturing expertise, vast technical knowledge and the ability to develop specific solutions and customize machines to customers' individual needs. Furthermore, Tornos meets electronic component manufacturers' needs with its hydrostatic technology delivering good surface finishes on multispindle applications, as well as finite element analysis for single-spindle applications.



*The more challenges
you overcome, the
greater your success.*

Electronics pervade our daily lives. They help us overcome our challenges, beginning with the digital alarm clocks that wake us up in the morning and the high-end coffee machine that yields that first cup of aromatic coffee. These components are found in the electronic locks on the doors of homes, our watches and smart wearables, the smartphones that are so ubiquitous today, our laptop computers, and the cameras with which we capture special moments.

With Tornos' legendary electronic component manufacturing expertise, it's not surprising that—almost everywhere we look—there's an electronic device with components that were machined with Tornos technologies. And every one of those devices demonstrates why electronics industry leaders continue to turn to Tornos for solutions to help them overcome their challenges and ensure their success.

Lock up your success in home security with Tornos

GONE ARE THE DAYS WHEN THE TYPICAL HOME WAS LEFT UNLOCKED. HOME SECURITY IS A RISING CONCERN AND PERFECTLY MANUFACTURED DOOR LOCKS PROTECT BOTH YOUR POSSESSIONS AND YOUR PEACE OF MIND.

Tornos keeps homes safe thanks to our experience in the lock industry. Our expertise extends from the key to the complete lock body, including gears that are precisely and efficiently machined from a wide variety of materials with Tornos technology. Fully customized brass parts are a key competence of our solutions—but our expertise doesn't end with brass. Our smart clamping solutions enable you to produce the full lock body and—as electronic lock systems become increasingly complex—our portfolio of turning solutions positions you to produce the market's most demanding locks today and well into the future.

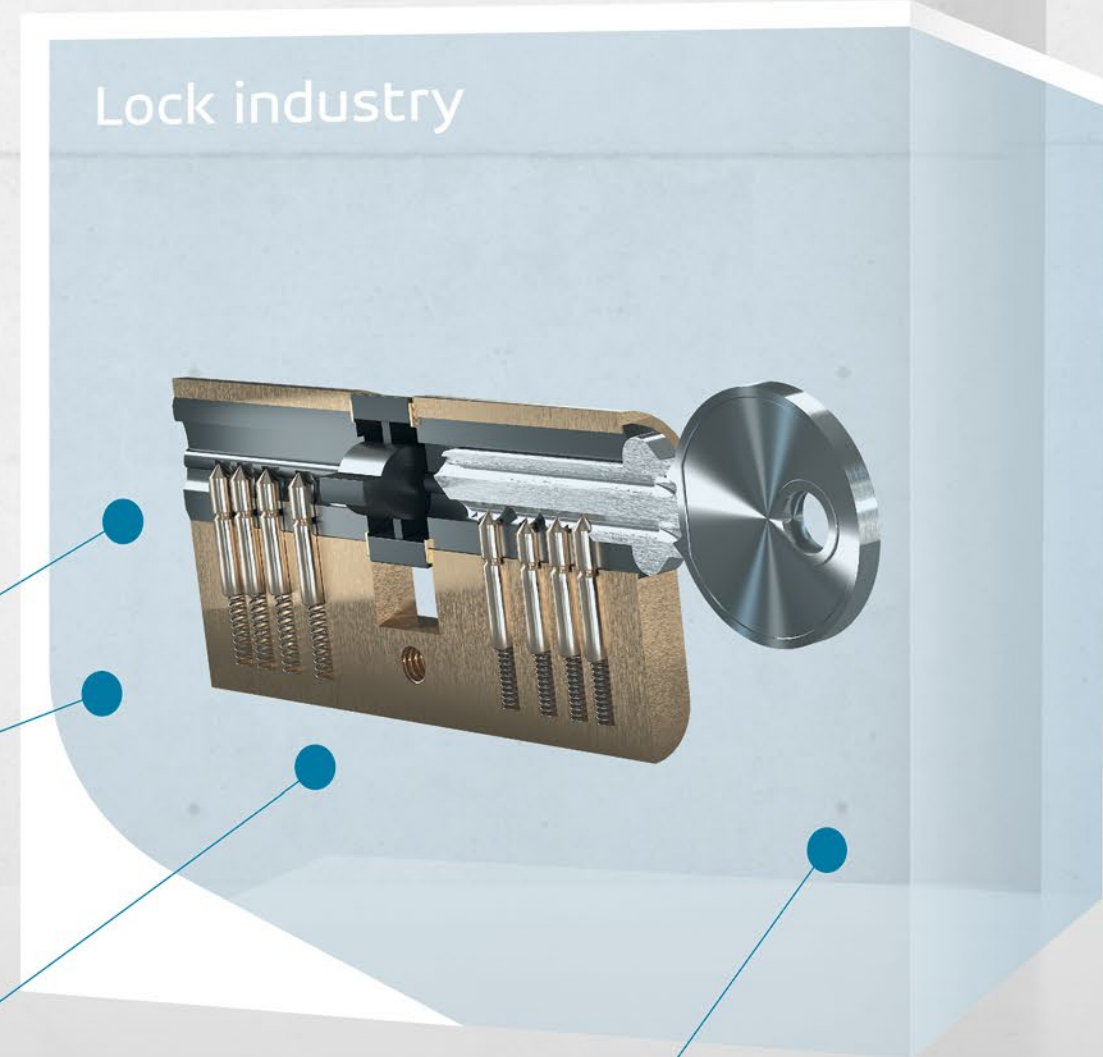

Our solutions add quality to everyday household goods

THE QUALITY AND RELIABILITY OF ORDINARY HOUSEHOLD AND LIFESTYLE GOODS, LIKE COFFEE MAKERS, CAMERA TRIPODS, MANUAL PASTA MACHINES AND EVEN MUSIC EQUIPMENT, HELP SHAPE OUR LIVES FOR THE BETTER—AND TORNOS MAKES A BIG CONTRIBUTION.

From the machine that brews the morning's first cup of coffee to high-end camera tripods, turned parts are everywhere in the world today. From home appliances to professional equipment, Tornos' solutions deliver the same unerring quality to advance your success in electrical and electronics manufacturing.



Behind virtually every smartphone, there's Tornos' expertise

FROM HIGH-END SMARTPHONES THAT DO IT ALL TO SIMPLE, BUDGET-LEVEL MOBILE PHONES, MOBILE COMMUNICATION DEVICES ARE UBIQUITOUS IN TODAY'S EVER-CONNECTED WORLD. WHEREVER THERE'S A SMART DEVICE, THERE'S A TORNOS PART.

Whether it's a high-end smartphone or a less expensive, basic model, virtually all contemporary smart devices have a part made on a Tornos machine. From turned parts for the camera of the iPhone 5 to volume and locking buttons, internal holding components and brackets, our solutions deliver the precision, finishes and design-elevating quality you expect.

Backed by our legendary service to world-class watchmakers, Tornos has the expertise in machining stainless steel to ensure the high quality and aesthetics your customers demand. High quality in high volumes is no problem with Tornos at your side.

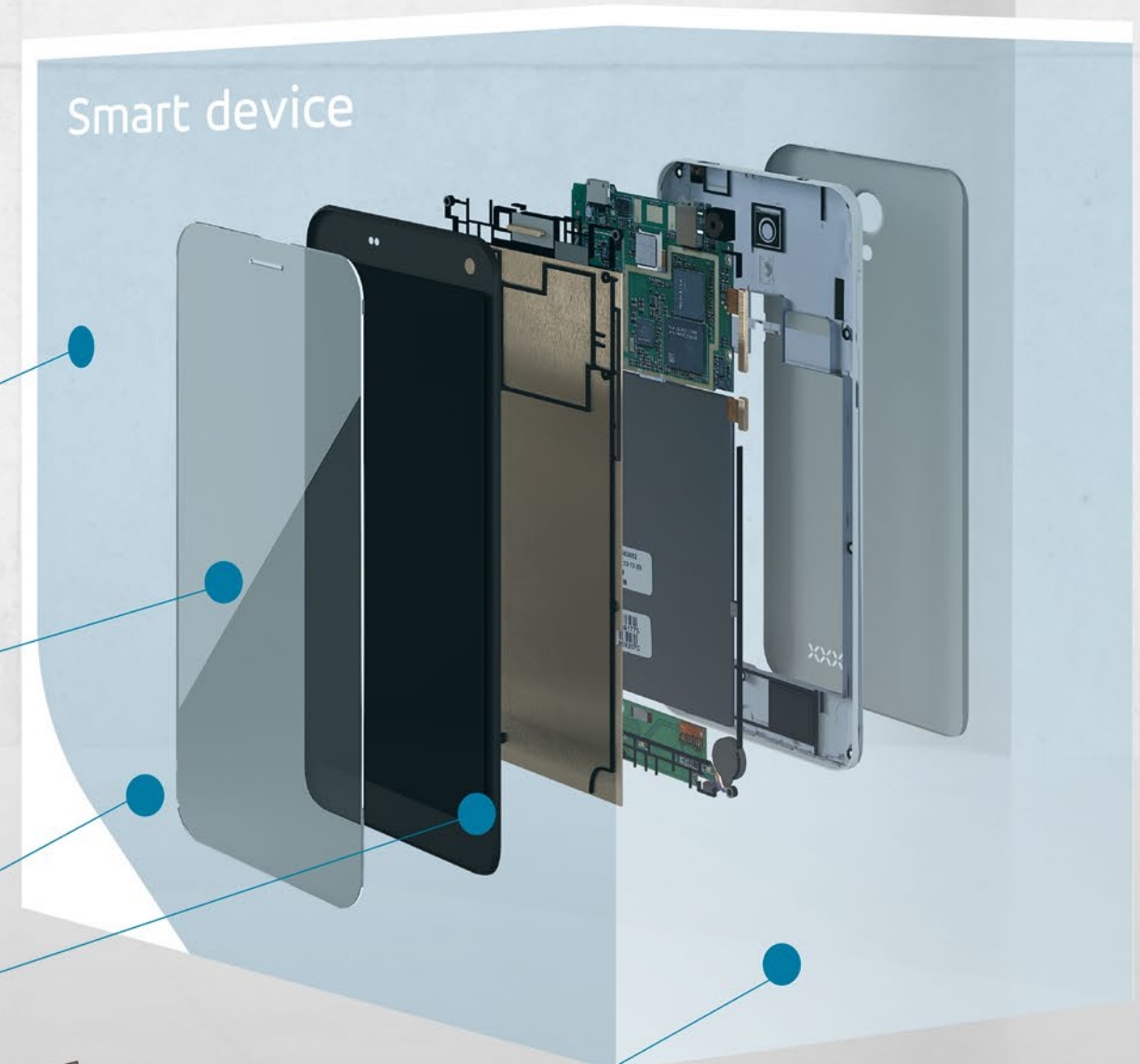

Tornos is your go-to expert for innovation-driving solutions

LASER AND OXYFUEL CUTTING ARE FINDING INCREASING USE IN INDUSTRY. MANUFACTURING THE COPPER PARTS FOR LASER AND OXYFUEL CUTTING DEVICES IS BECOMING INCREASINGLY PRECISE AS THE PROCESS ITSELF IS REFINED. TORNOS HAS THE GO-TO EXPERTISE FOR MANUFACTURING THESE INDUSTRIAL SOLUTIONS.

Electronics manufacturers are under continuing pressure to deliver new, innovative solutions in shorter cycle times, at lower costs and with greater quality—and laser and oxyfuel systems help them do it. Manufacturers of these systems rely on Tornos technologies to machine their machines' highly precise and durable copper components.

Tornos' precise and highly productive machines—backed by a vast array of services—are laser and oxyfuel system manufacturers' solutions of choice.

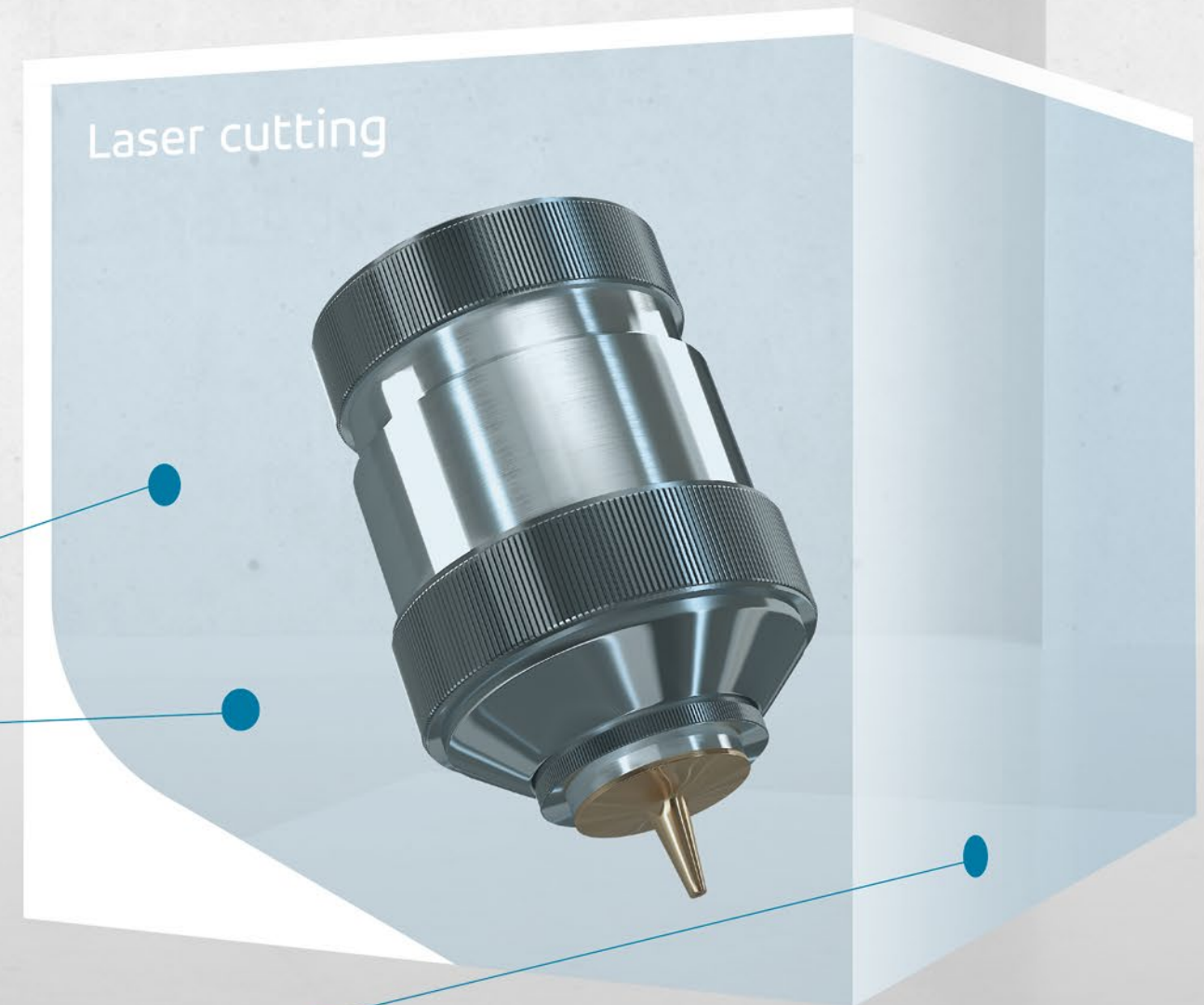
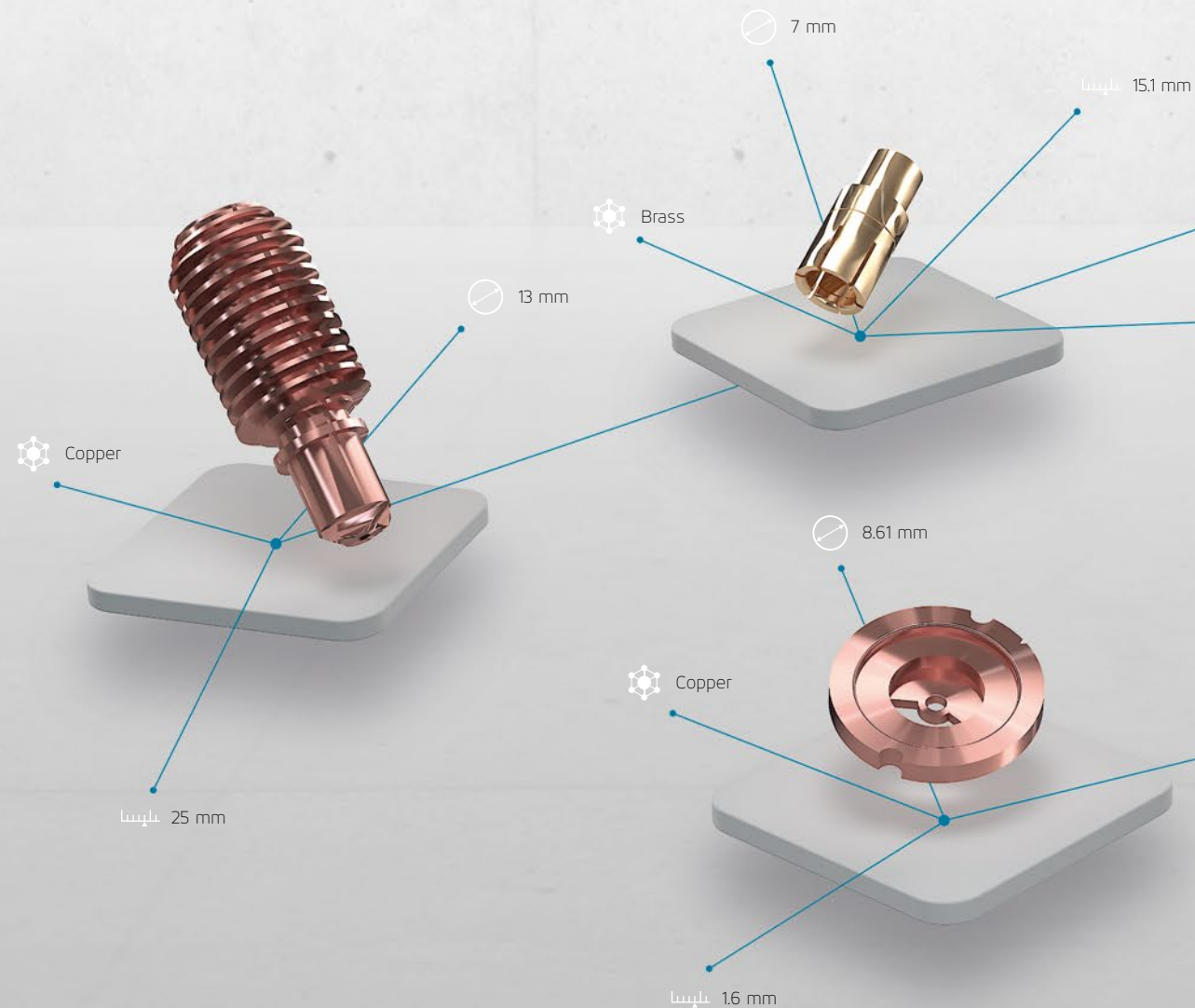

With a solution for every challenge, we secure our customers' application success, operational up time, quality, and efficiency.

Solution: high-pressure coolant

Increasing the coolant pressure has a positive effect on both chip breaking and tool life. Tornos' high-end machines designed for high productivity have a tool holder with fixed nozzles to enable high precision of the coolant supply at the cutting edge of the insert, a direct route to excellent chip breaking, process security and high productivity. Coolant delivery optimizes the machine capabilities and further improves tool life and chip formation. Since early 2000, machine builders have increased the pressure and flow on their machines each year, resulting in increased

electrical power consumption. With our latest products, Tornos has defeated this dilemma with built-in coolant that increases precision in the oil jet to reduce the flow and, consequently, reduce energy consumption of the machine while achieving the same highly precise results. The coolant jet has four main effects:

- To cool the insert in the contact zone
- To quickly force the chip away from the insert face, reducing wear on the insert
- To help break the chip into smaller pieces and evacuate it from the cutting area
- For rough turning, a coolant pressure of 80 bars provides a longer tool life than with a regular pressure

Tool life—times seven

By applying a coolant pressure of 80 bars, tool life increases by seven times in the finishing operation. The wear value (VB) is lower after 33 minutes in cut with 80 bar pressure, than after less than five minutes with a conventional coolant pressure of 15 bar. For the roughing operations, tool life increased by approximately 40 percent when using high-pressure coolant.

Solution: thread whirling

When it comes to machining worm screws for electrical motors, Tornos' unique thread whirling expertise—acquired as a go-to partner to various manufacturers—is a strong asset. We are the only company offering this process on multispindle and single-spindle lathes.

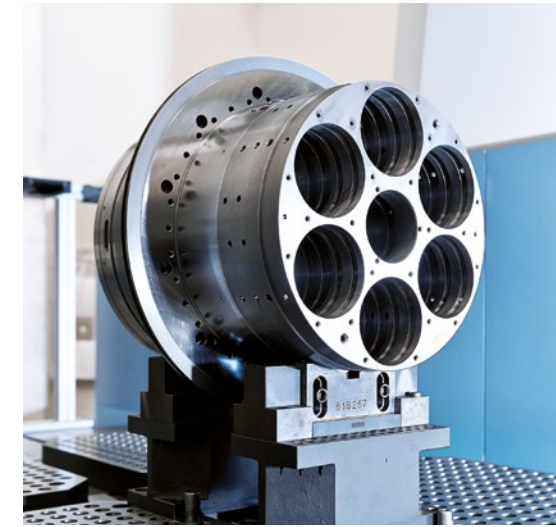

Solution: faultless quality

Consumers expect nothing less than the highest levels of quality and safety from their automotive electronics—and those expectations could well be described as absolutely standard. To ensure this level of quality, Tornos partners with specialists in controlling and measuring procedures and has developed an interface that is able to communicate with various types of measuring systems. Data from this interface is made available to suppliers of these systems who then adapt them. This partnership guarantees total compatibility between the machine and the measuring system for the operator who, as a result, has one less major issue. This interface is available on single- as well as multispindle machines and allows corrective data to be transmitted. If the measuring system detects a gradual drift from input data—due to tool wear, for example—a corrective measure is automatically triggered by the turning machine's control unit. In this way, the operator can monitor both tool wear parameters and any sudden shift from an input dimension resulting from tool failure, because in this case the system automatically actuates an alarm and can stop the machine.

Solution: Robot Cell i4.0

Delivering Industry 4.0-level autonomy and quality, Robot Cell i4.0 demonstrates how Tornos and its partners, Sylvac and JAG, are shaping a more efficient future for electronics manufacturers.

This future-shaping, automated production cell technology advances manufacturing productivity, quality and autonomy by eliminating human error. Robot Cell i4.0 is a single solution for cleaning, measuring, making in-process machining correction and storage of as many as four batches of your valuable parts.

Turn up to four Tornos machines into a state-of-the-art production cell with one solution. Your parts produced on Tornos machines are transferred to the cell for cleaning, and their orientation is detected by a camera, so the robot knows front from back.

Measurement is made easy by this solution: The cell extracts sample parts for measurement and unsampled parts are directly palletized. Then, the sampled parts are optically measured and the data is stored. With Robot Cell i4.0's closed-loop monitoring, all essential machining corrections are sent directly to the appropriate Tornos machine and all data is stored to guarantee full traceability—a growing must-have in various industrial segments. After measurement, compliant parts are stored and non-compliant parts are discarded. Your perfect parts, once ready, are stored in the magazine.

Connecting you to success

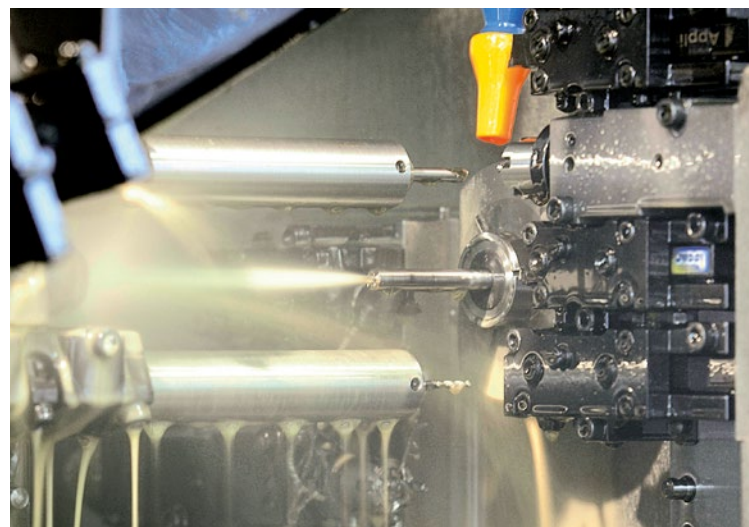

Tornos Service

Backed by both geographical proximity to you and a keen understanding of your processes, applications and market challenges, Tornos Service delivers an unparalleled continuum of support: start-up assistance; expert training and coaching; free hotline; on-site operations support and preventive maintenance; original spare parts seamlessly delivered worldwide; complete overhauls to extend the longevity of your Tornos machines; and a range of operations and upgrades to expand your application capabilities and profitability.

Buying a Tornos machine is much more than a business transaction. It is your investment in the future. Tornos Service thrives worldwide on securing the predictably high production capability of products carrying the Tornos name.

Situated close to you, as demonstrated by the 14 Tornos Service Centers strategically located across Europe, Asia, and the Americas, Tornos Service offers a full continuum of authoritative support for you and your Tornos machines, and encompasses the innovation, reliability and attention to detail expected of a premier Swiss brand. And it is all backed by more than 125 years of expertise and in-depth understanding of your processes, applications and challenges across a wide range of industrial segments, including Automotive, Medical & Dental, Electronics, and Micromechanics.

Start-up assistance

From the first feasibility tests prior to purchase, you are in good hands with Tornos Service. In our state-of-the-art Customer Centers, expert application engineers support you with tests to gauge the feasibility of machining processes and applications. With start-up assistance, you are secure in the knowledge that you will never be left alone to deal with a brand-new machine.

Expert training and coaching

Engineered for intuitive and easy use, Tornos machines offer a vast range of options and enable myriad processes. Expert training and coaching help your employees become programming, handling and maintenance experts, adding more value to your processes, applications and products.

Free Hotline support

Wherever you are in the world, highly qualified specialists who speak your language and understand your processes are just a phone call away to quickly support you with handling and programming solutions.

On-site support

Fast, efficient on-site operations and preventive maintenance ensure the continuous high performance of your Tornos machines. Regular scheduled preventive maintenance can help you avoid 70 percent of machine breakdowns and keep you on the path to productivity.

Certified original spare parts

Rapid, reliable, worldwide delivery of certified original Tornos spare parts is a specialty of Tornos Service. Regardless of the age of your Tornos machine, we stock the essential certified spare parts to keep the machine running at peak performance.

Machine overhauls

Tornos machines inspire confidence, so it's no surprise that many customers turn to Tornos for complete overhaul of their workhorse machines. Tornos' overhaul service returns the machines in good-as-new condition, appreciably extending their longevity.

Options and upgrades

To help you achieve your manufacturing, productivity and quality objectives, our experts collaborate with you to manage complex machining processes, develop software features for machining complex shapes, design special equipment, and tailor peripherals to your needs.

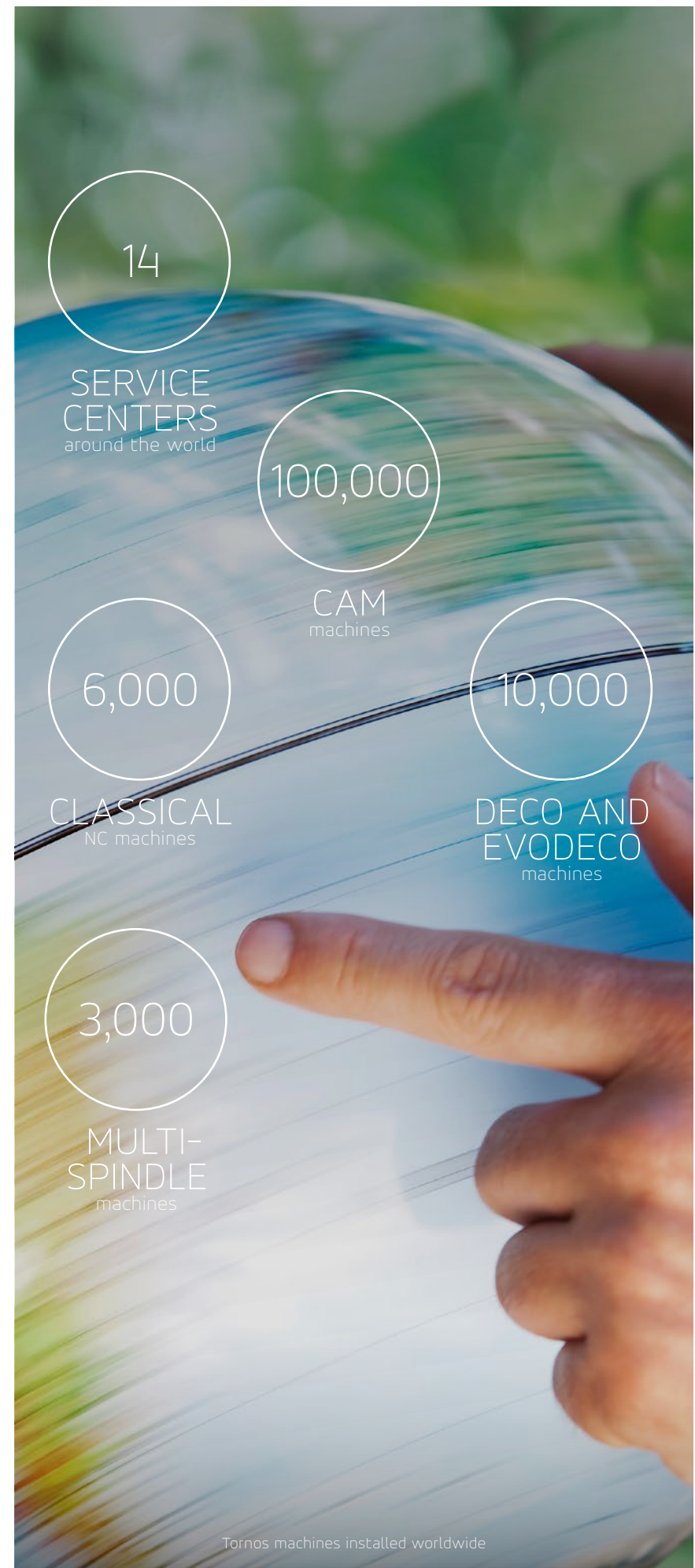

Discover
Tornos Service

A global footprint

Rooted in Switzerland, Tornos' global footprint keeps us close to you. Economy, flexibility and efficiency are the most important premises of the Tornos Group's production and assembly network.

Lean assembly and careful use of resources are the guiding principles behind all Tornos production planning and an integral part of the entire production process.

The same consistent quality standards are enforced at all locations around the globe. Intelligent linking of knowledge between our plants, along the commitment and know-how of our employees—enable production to begin right on time.

Wherever you are in the world, we keep you turning.



La Chaux-de-Fonds

Tornos La Chaux-de-Fonds is renowned for its high-quality bespoke solutions in the field of micro-milling. We create turnkey solutions to your technical specifications. Each machining centre has its own characteristics when it leaves the production plant.



Xi'an

Our Xi'an, China site's special testing and development center allows it to fit out machines to customer specifications. In Xian, we produce standard products delivering great value for the money on a global scale.



Moutier

Our Moutier site—using the latest production technologies and equipment—produces the key components of our world-renowned machines and assembles our high-end automatic turning machines and other multispindle solutions. Key components stamped “made in Switzerland” are produced in Moutier for all of our production sites.



Taichung

In Taichung, Taiwan—a city with a long machine tool-making tradition and broad network of suppliers—Tornos produces mid-range machines. Our Taichung facility's services include customization, setup, designing models, and on-site testing of machines produces. Key components of our machines produced in Taichung are sourced from our Moutier production site.

Truly best value goes beyond calculations like ROI and total cost of investment to deliver optimal life cycle cost.

IT'S NO WONDER RENOWNED ELECTRONICS MANUFACTURERS AND THEIR SUPPLY PARTNERS CHOOSE OUR TECHNOLOGIES, PRODUCTS, EXPERTISE AND SERVICES.

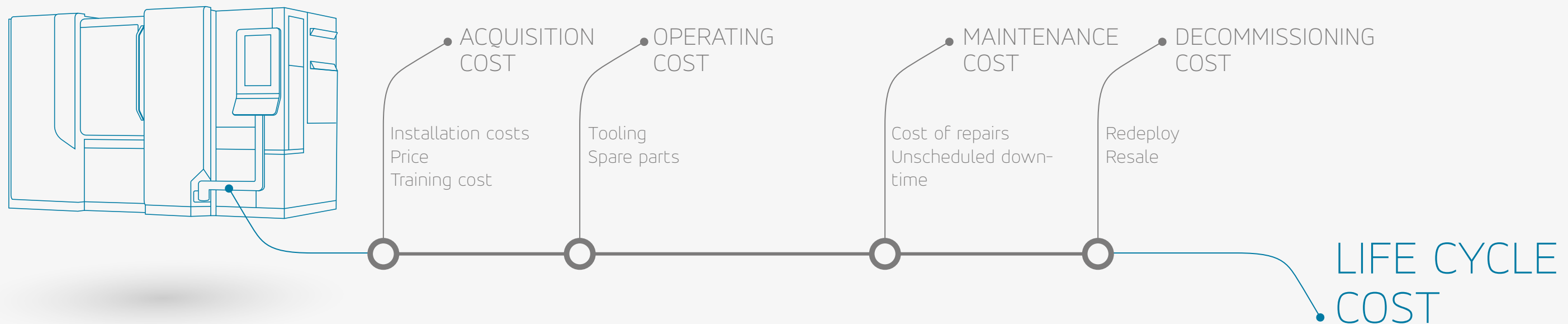

In the face of myriad electronics industry opportunities and challenges, **Tornos keeps suppliers turning with solutions that ensure appreciable return on investment (ROI)**. Manufacturers often focus only on equipment price when calculating ROI, not taking into account the total life cycle cost or anticipated performance of the equipment. The price-only philosophy can make you forget the reality that acquisition, operating, maintenance and decommissioning costs can all affect a machine's true cost.

Tornos solutions continue to serve you well beyond the classical five-year amortization period. Our machines are designed to withstand years of heavy-duty production.

A low-cost machine is fully depreciated after three or four years, so it looks inexpensive on the accounting books. This type of thinking leads many manufacturers to keep the machine running in the shop long after it should be retired.

A lower-cost machine leads to high maintenance costs, insufficient part quality and increased waste of material and parts. After three years, such a machine has minimal value. In contrast, **a high-performance Tornos machine can extend component life and reliability, reduce maintenance costs and retain 50 percent of its value on the used market at the end of three years.** These benefits should be factored into actual ROI.

Price is only one facet of a machine's cost, as the life cycle cost model illustrates well:

Costs considered:

- Price
- Cycle time

Costs usually ignored:

- Product performance
- Product life cycle
- Financing costs/cash flow
- Tooling
- Unplanned downtime
- Repair costs
- Labor
- Waste
- Redeployment costs
- Administrative costs
- Installation
- Utilities (software, etc.)

We keep you turning



tornos.com

TORNOS LTD

Rue Industrielle 111
CH-2740 Moutier
Phone +41 (0)32 494 44 44
contact@tornos.com

Tornos
throughout
the world

